

GRUA TORRE / TOWER CRANE

GRUE A TOUR / БАШЕННЫЙ КРАН /

رافعة برجية / KULE VINÇ

J4510



EN 14439
C25

UNE-EN-ISO 9001

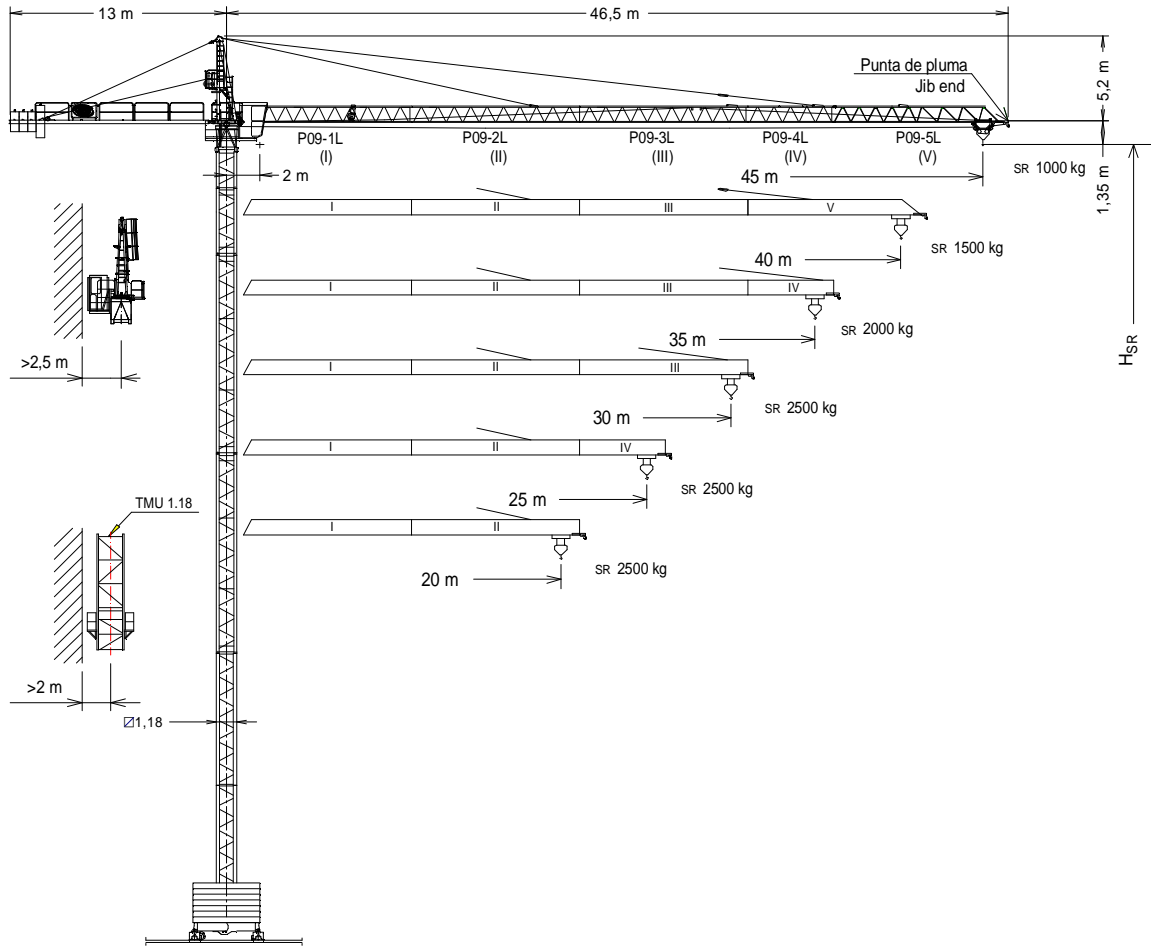

<p>Altura máxima bajo gancho sin arriostrar (m). Maximum height under hook without fastening (m). Hauteur maximale sous crochet sans ancrage (m). Максимальная высота под крюком без крепления (m). Bağlantısız maksimum kanca altı yüksekliği (m). أقصى ارتفاع تحت الخطاف بدون ربط (m)</p> <p>$H_{SR} =$</p>  <p>$H_{SR} - 2\text{ m}$.</p>	TMU 1.18 -----202.35.500	TN2 -----146.32.500
	P09-1L -----155.40.000	BTX 45/BEX 45 -----137.20.500
	P09-2L -----155.41.000	BTX 38R/BEX 38R -----137.20.000
	P09-3L -----155.42.000	BTX 38/BEX 38 -----149.20.000
	P09-4L -----155.43.000	BEX 45L -----155.23.500
	P09-5L -----155.44.500	BEX 38RL -----155.23.800
	Punta de pluma / Jib end* -----155.45.000	BEX 38L -----155.23.000
	TR 12 -----146.30.000	ABH 75 -----152.23.000
	TN 12 -----146.31.000	ABH 90 -----146.23.000
	TR 8RM -----202.30.000	AR 12 -----137.21.000
	TR 8M -----146.30.800	AN 12 -----146.21.000
	TR 4 -----800.32.300	BE 442 -----146.24.850
	TN 4 -----146.32.000	

* Punta de pluma / Jib end / Pointe de flèche / Конец стрелы / Ворс усу / مقدمة الذراع

(H) TRASLACIÓN / TRAVELLING /
TRASLATION / ПЕРЕМЕЩЕНИЕ / RAY YÜRÜYÜŞLÜ / متحركة

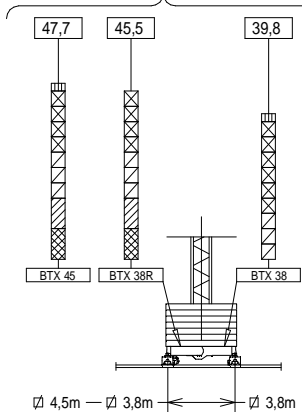

(H) ESTACIONARIA / STATIONARY /
STATIONAIRE / СТАЦИОНАРНОЕ СОСТОЯНИЕ / SABIT / ثابتة

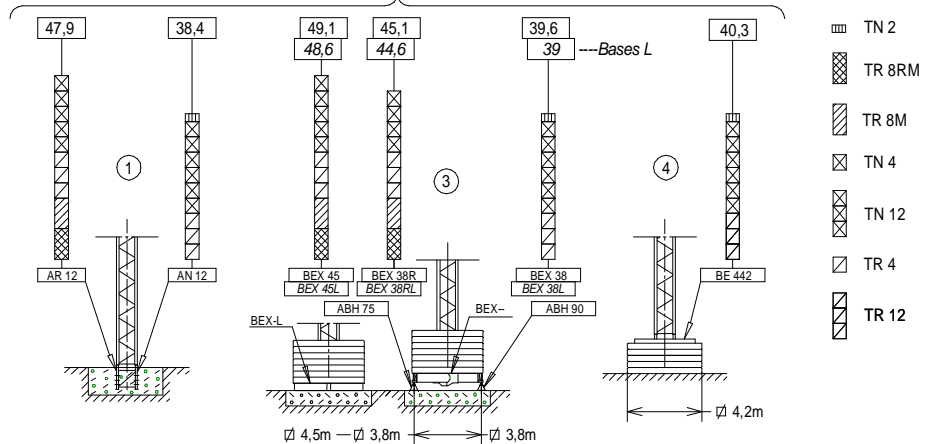



Fecha / Date: 20/01/2016

Reservado el derecho a modificaciones sin previo aviso. Declinamos toda responsabilidad derivada de la información proporcionada / Subject to modification, without previous warning. This information is supplied without liability / L'entreprise se réserve le droit de procéder à des modifications sans préavis. Nous déclinons toute responsabilité quant aux informations fournies / Мы оставляем за собой право на внесение изменений без предварительного уведомления. Мы снимаем с себя любую ответственность в отношении предоставленной информации / Önceden bildirilmeksizin değiştirilme hakkı saklıdır. Verilen bilgiler için hiçbir sorumluluk kabul etmemekteyiz





FEM 1005 - C25













CARGAS / LOADS / CHARGES / НАГРУЗКИ / YÜKLER / الأحمال **J4510**

	SR1 (kg)	Cargas máximas / Maximum loads / Charges maximales / Максимальные нагрузки / Maksimum yük / أقصى حمولة					
		SR1-2000 kg					
	2000 kg @...[m]	Alcance del gancho [m] / Hook reach [m] / Portée du crochet (m) / Радиус действия крюка (m) / Kancanın yüksekliği (m) / مدى الخطاف					
		20	25	30	35	40	45
45 m	25,0	2000	2000	1625	1355	1155	1000
40 m	31,1	2000	2000	2000	1750	1500	—
35 m	35,0	2000	2000	2000	2000	—	—
30 m	30,0	2000	2000	2000	—	—	—
25 m	25,0	2000	2000	—	—	—	—
20 m	20,0	2000	—	—	—	—	—

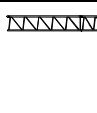

CARGAS / LOADS / CHARGES / НАГРУЗКИ / YÜKLER / الأحمال **J4510**

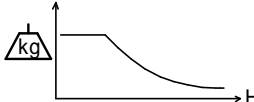
	SR2 (kg)	Cargas máximas / Maximum loads / Charges maximales / Максимальные нагрузки / Maksimum yük / أقصى حمولة					
		SR2-2500 kg					
	2500 kg @...[m]	Alcance del gancho [m] / Hook reach [m] / Portée du crochet (m) / Радиус действия крюка (m) / Kancanın yüksekliği (m) / مدى الخطاف					
		20	25	30	35	40	45
45 m	20,5	2500	2000	1625	1355	1155	1000
40 m	25,5	2500	2500	2085	1750	1500	—
35 m	28,6	2500	2500	2375	2000	—	—
30 m	30,0	2500	2500	2500	—	—	—
25 m	25,0	2500	2500	—	—	—	—
20 m	20,0	2500	—	—	—	—	—

CARACTERISTICAS DE MECANISMOS / MECHANISMS FEATURES / CARACTÉRISTIQUES DES MÉCANISMES / ХАРАКТЕРИСТИКИ МЕХАНИЗМОВ / MEKANİZMALARIN ÖZELLİKLERİ / الخصائص الآلية **J4510**

*opcional *optional *en option *опция *opsiyonel *اختياري								
	EC1846 SR2 13,2 kW	EC1856 SR1 13,2 kW	*EC2566VF SR2 18,4 kW	*EC2580VF SR1 18,4 kW	2,8/3,8 / 4,5m TG825VF 2x3 kW	OG608VF 4 kW	TC360 / *TC360VF 1,9 / *1,8 kW	TH1010 9,2 kW
	1,3 2,5 2,5 46 23 5	1,1 2 2 56 28 6	1,3 2,5 0..64 0..32	1,1 2 0..82 0..41	0...25 m/min	0... 0,8 r/min sl/min	30/60 m/min *0...30 *30...60 m/min	1 m/min
	H ≤ SR 193 m		SR 189 m		 P_{TOTAL}(EC1846/EC1856 + OG608VF + TC360) = 19,1 kW P_{TOTAL}(*EC2566VF/*EC2580VF + OG608VF + *TC360VF) = *24,2 kW 400V 50Hz			
					 EC1846 EC1856 TC360 TH1010 kW +20% m/min +20% 480V 60Hz			

LASTRES INFERIORES / LOWER BALLASTS / LESTS INFÉRIEURES / НИЖНИЙ БАЛЛАСТ / ALT AĞIRLIK TAŞLARI / نقل **J4510**

	H (m)	18	22	30	40	47,7	49,1
BEX 45 / BTX 45	 4100 kg	6		8	10	14	16
BEX45L		8		10	14	16	
BEX 38R / BTX 38R		6	8	10	12	16	----
BEX 38 / BTX 38		6	8	10	12	----	----
BEX 38RL		8	10	12	16	----	----
BEX 38L		8	10	12	----	----	----
	H (m)	31,9			40,3		
BE 442	 3450 kg	16			20		







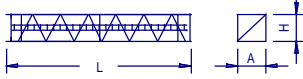
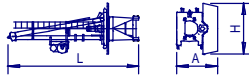
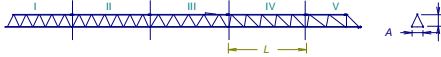

H: Altura bajo gancho / Height under hook / Hauteur maximale sous crochet / Высота под крюком / Kanca altı yüksekliği / الارتفاع أسفل الخطاف
 Para alturas intermedias tomar el lastre correspondiente a la altura superior / For intermediate heights take the ballast corresponding to the higher height / Pour les hauteurs intermédiaires, opter pour le lest correspondant à la hauteur immédiatement supérieure / Для промежуточных высот возьмите балласт, соответствующий большей высоте / Orta yükseklikler için daha üst bir yüksekliğe karşılık gelen ağırlığı alınız. / لارتفاعات البينية يرجى استخدام النقل العائد للارتفاع الأعلى. / للمعلومات المقدمة

Fecha / Date: 20/01/2016

 **FEM 1005 - C25**

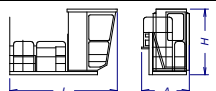

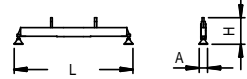
Reservado el derecho a modificaciones sin previo aviso. Declinamos toda responsabilidad derivada de la información proporcionada / Subject to modification, without previous warning. This information is supplied without liability / L'entreprise se réserve le droit de procéder à des modifications sans préavis. Nous déclinons toute responsabilité quant aux informations fournies / Мы оставляем за собой право на внесение изменений без предварительного уведомления. Мы снимаем с себя любую ответственность в отношении предоставленной информации / Önceden bildirilmeksizin değiştirilme hakkı saklıdır. Verilen bilgiler için hiçbir sorumluluk kabul etmemekteyiz / حقوق التغيير محفوظة دون إشعار مسبق. دون أدنى مسؤولية عن المعلومات المقدمة

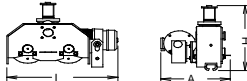
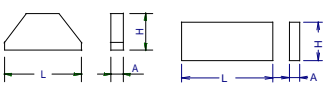
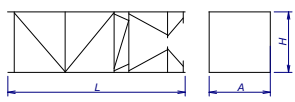
DENOMINACIÓN / DENOMINATION / DÉSIGNATION / НАЗВАНИЕ / AÇIKLAMA / اسم		L [m]	A [m]	H [m]	P / W [kg]
Torre Tower Tour Башня Kule برج	TR 8RM – TR 8M TR 12 – TN 12 TR 4 TN 4 TN 2				8,07 1,19 1,19 2575-2515 12,01 1,19 1,19 2840-2780 3,96 1,18 1,18 1070 4,09 1,19 1,19 1055 2,29 1,19 1,19 785
Conjunto asiento pista, punta de torre, orientación y elevación Slewing table assembly, tower head, slewing and hoisting mechanism Groupe pivot + porte-flèche + mécanisme d'orientation + de levage Сиденье площадки + верхняя секция башни + поворотный механизм + подъемный механизм Göbek +kulenin kafa bölümü+mekanizma+vinç kulesi مجموعة وحدة الدوارن + رأس البرج + آلية الدوران + آلية الرفع					6,97 1,65 2,42 3622
Tramo de pluma Jib section Tronçon de flèche Секция стрелы Bom bölümü أجزاء الذراع	P09 1L (I) P09 2L (II) P09 3L (III) P09 4L (IV) P09 5L (V)				10,13 1 1,15 650 10,13 0,86 1,09 550 10,15 0,86 1,09 565 5,26 0,86 1,09 250 10,12 0,86 1,09 407
Polipasto / Hook assembly / Palan / Полуснаст / Kanca takımı / بكرة	SR				0,76 0,16 0,96 135
Carro / Trolley / Chariot / Грузовая тележка / Şaryo / عربة	SR				1,00 1,33 0,73 110
Contrapluma con plataformas / Counterjib with platforms Contre-flèche avec plateformes / Противовесная консоль с платформами / Platformlu kuzyuk / المنصة مع المقابل الذراع					11,95 1,35 0,4 942
Plataforma y cabina / Platform and cabin / Plateforme et cabine / Платформа и кабина / Platform ve kabin / منصة وكابينة					3,69 1,63 2,25 820
Contrapeso / Counterweight / Contrepoids / Противовес / Denge ağırlığı / اوزان معاكسة	Grande / Big / Grand / Большой / Büyük / كبير Pequeño / Small / Petit / Малый / Küçük / صغير				1,08 0,50 2,02 2360 1,08 0,50 1,30 1500
Base grúa Testero largo Crane base Long carriage Base de la grue. Palonnier long Основание крана. Длинная передняя часть Vinç tabanı. Uzun vinç arabası قاعدة الرافعة بمقدمة طويلة (للكابينة)	BTX 38 BTX 38R BTX 45				6,11 0,64 1,53 1576 6,11 0,64 1,57 1792 7,01 0,64 1,57 2065
	BTX 38L BTX 38RL BTX 45L				5,46 0,55 0,97 1160 5,46 0,55 0,88 850 4,01 0,55 0,88 660
	BEX 38 BEX 38R BEX 45				5,56 0,3 1,27 1390 5,56 0,3 1,40 1590 6,55 0,3 1,41 1863
Mecanismo traslación grúa / Crane travelling mechanism Mécanisme de translation de la grue / Механизм перемещения крана / Yürüyüş mekanizmalı vinç آلية رفع الرافعة					0,96 0,56 0,66 293
Lastre / Ballast / Lest / Балласт / Alt ağırlık taşları / ثقل	□ 2,8m □ 3,8m □ 4,5m BE 442 BE 434				3,00 0,44 1,30 3700 4,00 0,34 1,30 4100 2,09 0,34 2,10 3450 3,40 0,34 1,69 4300
Torre de montaje / Jacking cage / Tour de montage / Монтажная башня / Kaldırma kafesi / التركيب					7,14 1,76 1,71 3200
Torre de montaje sin puerta, carro, plataforma carro y viga de apoyo Jacking cage without door, trolley, trolley platform and beam assembly Tour de montage sans porte, chariot, plateforme de chariot et poutre de soutien Монтажная башня без двери, грузовой тележки, платформы грузовой тележки и опорной балки Kapisız kaldırma kafesi, vinç köprüsü arabası, vinç köprüsü arabası platformu ve kiriş takımı برج التركيب بدون بوابة ، و عربة ومنصة متحركة و عارضة تدعيم	TMU 1.18				7,14 1,76 1,71 2450

T	H	Component	Weight (kg)	T	H	Component	Weight (kg)	T	H	Component	Weight (kg)	T	H	Component	Weight (kg)
1	4,5	TN 4	146.32.000	1	4,5	TN 2	2,16	1	2,7	TN 4	146.32.000	1	4,5	TN 4	146.32.000
2	8,5	TN 4		2	6,6	TN 4	3,96	2	6,6	TN 4		2	8,5	TN 4	
3	20,3	TN 12	146.31.000	3	18,5	TN 12	11,88	3	18,5	TN 12	146.31.000	3	20,3	TN 12	146.31.000
4	32,2	TR 12	146.30.000	4	30,4	TR 12	11,88	4	30,4	TR 12	146.30.000	4	32,2	TR 12	146.30.000
5	40,1	TR 8M	146.30.800	5	38,3	TR 8M	7,86	5	38,3	TR 8M	146.30.800	5	40,1	TR 8M	146.30.800
6	43,9	TX-90/TXXR	202.36.500	6	42,1	T 3-90	0,83	6	42,1	TX-90/TXXR	202.36.500	6	43,9	TX-90/TXXR	202.36.500
7	46,8	T 3-90	133.32.000	7	45,0	T 3-90	2,95	7	45,0	T 3-90	133.32.000	7	46,8	T 3-90	133.32.000
8	49,8	T6-150A	161.31.300	8	48,0	T6-150A	5,82	8	50,8	T6-150A	161.31.300	8	49,8	T6-150A	161.31.300
9	52,7	T6-150	161.31.000	9	53,8	T6-150	56,6	9	56,6	T6-150	161.31.000	9	52,7	T6-150	161.31.000
		AN 90	133.21.000	10	59,6	TL20/TX150	3,93	10	60,5	TL20/TX150	161.36.000	10	59,6	TL20/TX150	161.36.000
		AN 150	161.21.000	11	63,5	TL20-5,6	5,6	11	66,1	TL20-5,6	204.31.400	11	63,5	TL20-5,6	204.31.400
		AL 20	153.21.800	12	69,2	TS20-5,6A	5,6	12	71,7	TS20-5,6A	204.31.500	12	69,2	TS20-5,6A	204.31.500
		ALD 20	160.21.250			AS 20	5,6	13	77,3	AS 20	204.31.200	13		AS 20	204.31.200
		AS 20	160.21.010			ASR 20	5,6	14	84,8	ASR 20	204.31.000	14		ASR 20	204.31.000
		ASD 20/24	160.21.080												
		ASRD 20/24	156.21.000												

H = 2 m.

T: Torre / Tower / Tour / Башня / Kuleler / أبراج
 H: Altura / Height / Hauteur / Высота / Yükseklik / ارتفاع

Otras configuraciones de torre / Other tower configuration / Autres configurations / Прочие конфигурации / Diğer konfigürasyonlar / مكونات أخرى

Transporte / Transport / Транспортировка / Taşıma / نقل

H=38,4 + AN12

2x [Truck icon]

3x HIGH CUBE 40'

≤ 6xTN4

TREPADO / CLIMBING / TÉLESCOPAGE / ЛЕСТНИЦА / TIRMANMA / التسلق J4510

$h_{max} = 3 \times TR4 + 6 \times TN4$

h (m)	36
D (m)	8,6 - 10
P (KN)	319 / 294
Rmax (KN)	88 / 250

TR4: 800.32.300

H < 200 m

Trepado interno / Internal climbing. / Télescopage intérieur / Внутренняя лестница / Bina içi tırmanma / التسلق الداخلي

- ⚠ Viento fuera de servicio / Out of service wind / Vitesse du vent hors service / Ветровая нагрузка в покое / Rüzgar devre dışı / الريح خارج الخدمة
- 📄 Consultar / Consult / Nous consulter / Консультируйтесь / Danışınız / الرجوع إلى
- ▶ En servicio / In service / En service / В работе / Devrede / في الخدمة
- Fuera de servicio / Out of service / Hors service / В покое / Devre dışı / خارج الخدمة



Ctra./Rd. Madrid - Irún Km. 415 - 20.213 IDIAZABAL [Gipuzkoa] ESPAÑA / SPAIN
 P.O. Box, 23 - 20.200 BEASAIN - E-mail: jaso@jaso.com
 Tel. +34 943 - 18 70 00 • Fax. +34 943 - 18 70 20
www.jaso.com

Fecha / Date: 20/01/2016

FEM 1005 - C25

DELEGACION / DEALER

Reservado el derecho a modificaciones sin previo aviso. Declinamos toda responsabilidad derivada de la información proporcionada / Subject to modification, without previous warning. This information is supplied without liability / L'entreprise se réserve le droit de procéder à des modifications sans préavis. Nous déclinons toute responsabilité quant aux informations fournies / Мы оставляем за собой право на внесение изменений без предварительного уведомления. Мы снимаем с себя любую ответственность в отношении предоставленной информации / Önceden bildirilmeksizin değiştirilme hakkı saklıdır. Verilen bilgiler için hiçbir sorumluluk kabul etmemekteyiz /

حقوق التغيير محفوظة دون إشعار مسبق. دون أدنى مسؤولية عن المعلومات المقدمة